



REFRIGERATION

SERVING THE FOOD INDUSTRY SINCE 1951

COUNTERTOP / DROP-IN CURVED GLASS REFRIGERATED DISPLAYS

Item: 36514
Model: RS-CN-0173

Item: 36515
Model: RS-CN-0218



DISPLAY YOUR FAVOURITE DELIS WHILE KEEPING THEM FRESH AND SANITARY

Omcan's Countertop / Drop-in Curved Glass Refrigerated Displays are perfect for supermarkets, sandwich shops, and pizzerias. With their smooth, attractive, curved glass design, they are perfect for displaying cheese, meat, and other refrigerated deli items while maintaining your products fresh and sanitary.



WARRANTY
PARTS AND LABOR



SHIPPED ON PALLET



Applies to item 36514 only

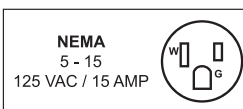

Authorized Dealer

REFRIGERATION

47-INCH COUNTERTOP / DROP-IN CURVED GLASS
REFRIGERATED DISPLAY - 6.10 CU. FT. CAPACITY



FEATURES

- #304 Stainless Steel exterior and interior
- Forced air circulation system
- High quality digital temperature controller
- Middle or High back pressure hermetic compressor
- Automatic defrost system
- R134a Gas, Ozone friendly
- Drop-In style
- Single rear access
- QPS Approved

TECHNICAL SPECIFICATIONS

ITEM NUMBER	36514
MODEL	RS-CN-0173
TEMPERATURE RANGE	2°C - 8°C / 35.6°F - 46.4°F
CAPACITY (L / CU. FT.)	173 L / 6.1 cu. ft.
POWER	0.408 kW
CURRENT	4.12A
REFRIGERANT	R134a, 270g
NUMBER OF SHELVES	2
ELECTRICAL	110V / 60Hz / 1Ph
INTERIOR DIMENSIONS (DWH)	14.25" x 41" x 15" 361.95 x 1041.4 x 381 mm
BASE DIMENSIONS (DWH)	18.1" x 44.9" x 8.35" 459.74 x 1140.46 x 212.09 mm
DIMENSIONS (DWH)	21.25" x 47.25" x 31.5" 539.75 x 1200.15 x 800.1 mm
PACKAGING DIMENSIONS	51.75" x 25.40" x 40" 1314.45 x 645.16 x 1016 mm
WEIGHT	231.5 lbs. / 105 kg.

TECHNICAL DRAWINGS AND DIMENSIONS

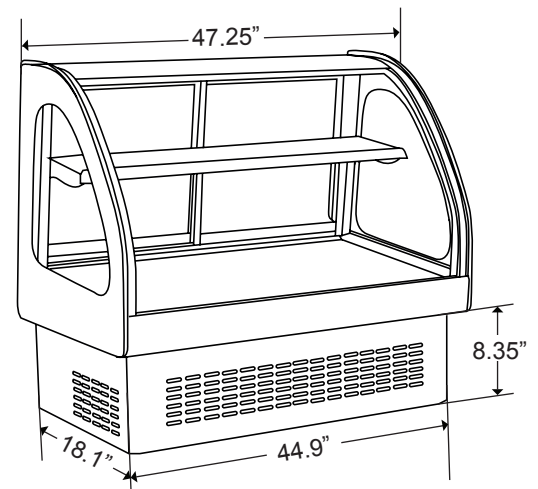
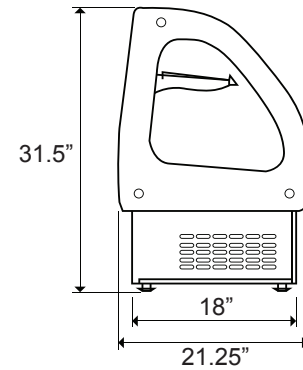

OMCAN INC.

Telephone: 1-800-465-0234
Fax: (905) 607-0234
Email: sales@omcan.com
Website: www.omcan.com



Follow us to keep up to date with the latest news and offers



2016.E.O.E

REFRIGERATION

59-INCH COUNTERTOP / DROP-IN CURVED GLASS
REFRIGERATED DISPLAY - 7.70 CU. FT. CAPACITY



FEATURES

- #304 Stainless Steel exterior and interior
- Forced air circulation system
- High quality digital temperature controller
- Middle or High back pressure hermetic compressor
- Automatic defrost system
- R134a Gas, Ozone friendly
- Drop-In style
- Single rear access

TECHNICAL DRAWINGS AND DIMENSIONS

TECHNICAL SPECIFICATIONS

ITEM NUMBER	36515
MODEL	RS-CN-0218
TEMPERATURE RANGE	2°C - 8°C / 35.6°F - 46.4°F
CAPACITY (L / CU. FT.)	218 L / 7.70 cu. ft.
POWER	0.420 kW
CURRENT	4.24A
REFRIGERANT	R134a, 300g
NUMBER OF SHELVES	2
ELECTRICAL	110V / 60Hz / 1Ph
INTERIOR DIMENSIONS (DWH)	14.25" x 52.75" x 15" 361.95 x 1339.85 x 381 mm
BASE DIMENSIONS (DWH)	18.1" x 56.7" x 8.35" 459.74 x 1440.18 x 212.09
DIMENSIONS (DWH)	21.25" x 59" x 31.5" 539.75 x 1498.6 x 800.1 mm
PACKAGING DIMENSIONS	63.40" x 25.40" x 40" 1610.36 x 645.16 x 1016 mm
WEIGHT	264.5 lbs. / 120 kg.

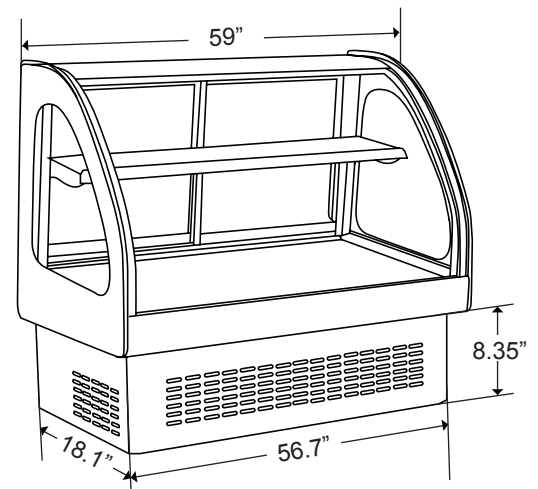
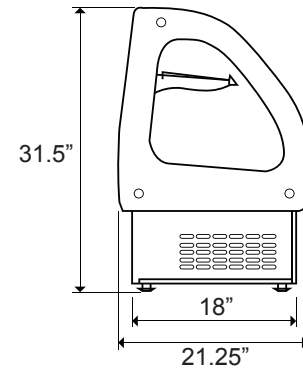

OMCAN INC.

Telephone: 1-800-465-0234

Fax: (905) 607-0234

Email: sales@omcan.com

Website: www.omcan.com



Follow us to keep up to date with the latest news and offers



2016.E.O.E